

Admiral Helms

Tired of fighting with the steering on your boat? Then let an Admiral put you in command.

HyDrive, Australia's largest selling hydraulic steering for small boats, offers the finest in smooth, powerful steering, with quality and materials that are built to last. Large horsepower outboards are handled with comfort and without feedback from engine torque.

It doesn't matter whether you have a small boat with a small outboard, or a larger craft with multiple V-8's, there is a HyDrive Admiral to suit. Everything you need to handle virtually any boat using outboards, inboards, sterndrives or jet units from 4-15 Metres - delivered in a single carton!

The heart of the new Admiral Series is the HyDrive Model 101 (28cc/rev) and 102 (35cc/rev) helm unit. These 7-piston pumps are precision manufactured to standards and tolerances that are second to none. In-built lock valves, which eliminate torque feedback are standard. The light, smooth steering must be experienced to be appreciated.

But why HyDrive?

While it's true that there are other hydraulic steering systems on the market, none of them have been built using the same salt-water resistant design criteria or give you the same value as HyDrive.

Designed as a complete Do It Yourself installation, everything you need is supplied including detailed instructions. You don't even have to know anything about hydraulics!

Just compare the list of features and then consider carefully which system you really want to fit on your boat.



ADMIRAL HELMS

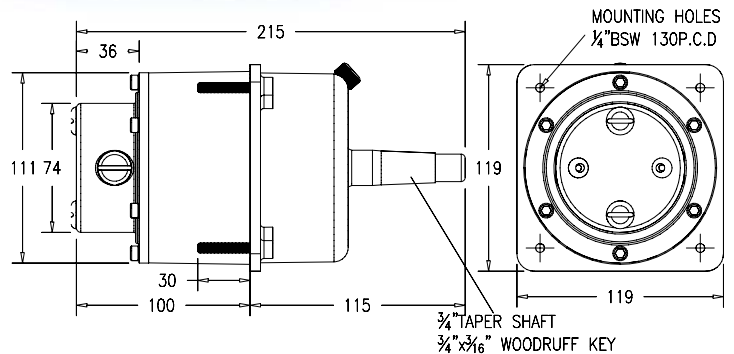

The Admiral Helm unit

- Compact, low-profile standard helm with minimal protrusion from the console
- Optional front mount or tilting helm style
- In-built lock-valve eliminates torque feedback. The wheel stays where you put it!
- Field replaceable shaft seal
- Solid stainless steel helm shaft for optimum strength and durability. Do not settle for "hardened alloy" (anodised aluminium)
- Superior material choice - even the wheel nut and washer are brass
- 4 precision bearings for smoothest performance
- All helms are built to High Performance standards - **you don't pay more for HyDrive Power!**



Front - mount design
Model 101 - FM or 102 - FM



Fully tilting helm design
Model 101 - Tilt or 102 - Tilt

